

Camino Modular Systems Inc. established in 1970 is an international supplier of access floor systems.

Head Office and Factory

89 Carlingview Drive
Toronto, Ontario, Canada
M9W 5E4
Tel: 416-675-2400 / 1-800-370-0226
Fax: 416-675-2424 / 1-866-370-0226

Mid West Regional Sales Office

Chicago, IL
Tel: 847-427-1800
Fax: 847-427-8173

Southern Regional Sales Office

Dallas, TX
Tel: 972-788-2770
Fax: 972-866-9160

West Coast Regional Sales Office

Vancouver, BC
Tel: 604-267-2400
Fax: 604-267-2402

www.camino-access-floors.com

Camino access floors have been installed for many of the worlds leading companies, including:

A.C. Nielson
Air Canada
Allstate Insurance
Amdahl
AT&T
Bank of Moscow
Bank of Montreal
Bank of Nova Scotia
Banko Sandander
Bell Telephone
Cantel
Charles Schwabb
Chase Manhattan Bank
Chrysler
CIBC
Citicorp Bank
Clearnet
Coca Cola Ltd.
Credit Suisse
Dai Ichi Bank
Deacon Barclays Bank
Dean Witter

Department of Defense
Discovery Museum
Dow Chemical
Exxon
Ford Motor Company
FUJI
General Motors
Hewlett Packard
Hydro Quebec
IBM
Kenya International Airport
Labatt's Brewery
Loblaws Head Office
MacMillan Bloedel
Mayo Clinic
McDonnell Douglas
MCI
Microsoft
Ministry of Finance
Ministry of Transportation
Molson's Brewery
Morgan Guaranty Trust

Motorola
Ontario Hydro
Oracle Corporation
Pacific Bell
Pitney Bowes
Public Works Canada
RCMP
Rockwell International
Rogers Communications
RBC Royal Bank
Shell Oil
Société Immobiliere du Quebec
Société Générale
Sprint
Teleglobe
TD Bank
United Airlines
U.S. Air Force
U.S. Navy
Volkswagen
Union Bank of Switzerland

FS SERIES

ACCESS FLOOR SYSTEM



CAMINO

MODULAR SYSTEMS INC.

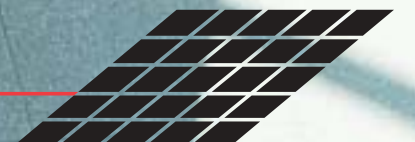

CAMINO

MODULAR SYSTEMS INC.



FS Series

Low Profile Access Floor System
Camino Flex Modular Wiring System

- Lower operating costs
- Increase productivity - less downtime
- Faster move-in
- Improve workplace aesthetics
- Technology flexible now...and in the future

Initial Cost

- Minimal impact on overall construction/FFE budget.
- Significant savings on renovation/conversion projects.
- Capital cost comparison study customized to your project is available upon request.

Operating Costs

Move, add, change without access flooring... \$1250.00*per station
 Move, add, change with access flooring...\$108.00 per station
SAVINGS PER CHANGE \$1142.00 per station

*Source IFMA

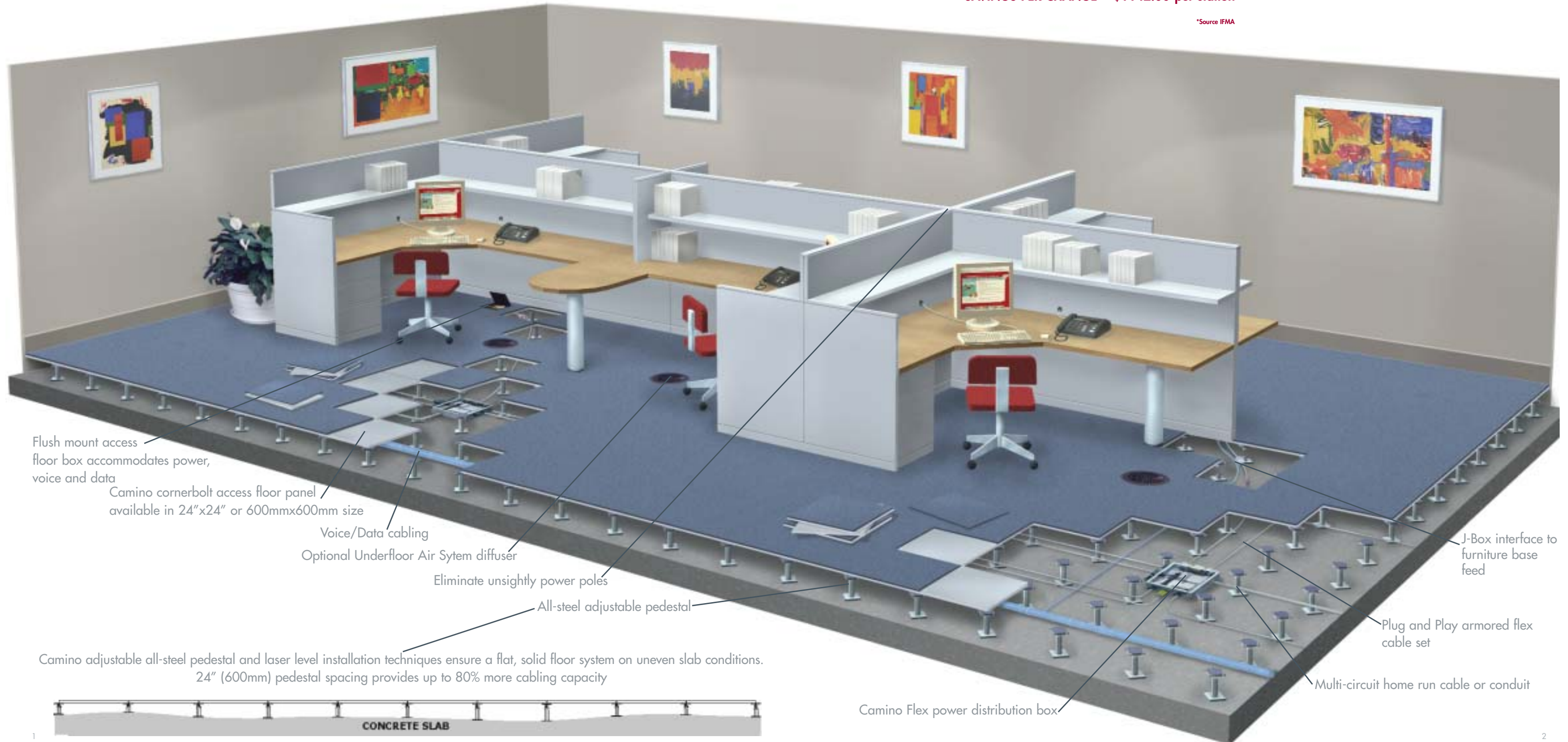

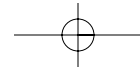

Unlimited Choice of Floor Heights

Exceptional Load Performance & Slab like Acoustics

SPEC INFO 1-800-370-0226

12" - 24"
Finished Floor Height

8" - 18"
Finished Floor Height

4" - 6"
Finished Floor Height

3"
Finished Floor Height

2 1/2"
Finished Floor Height



FS 1000
FS 1250
FS 1500



FS1000 Standard Duty (1000lbs./sq.in.)
FS1250 Medium Duty (1250 lbs./sq.in.)
FS1500 Heavy Duty (1500 lbs./sq.in.)
FS2000 Extra Heavy Duty (2000 lbs./sq.in.)
FS2500 Industrial Duty (2500 lbs./sq.in.)

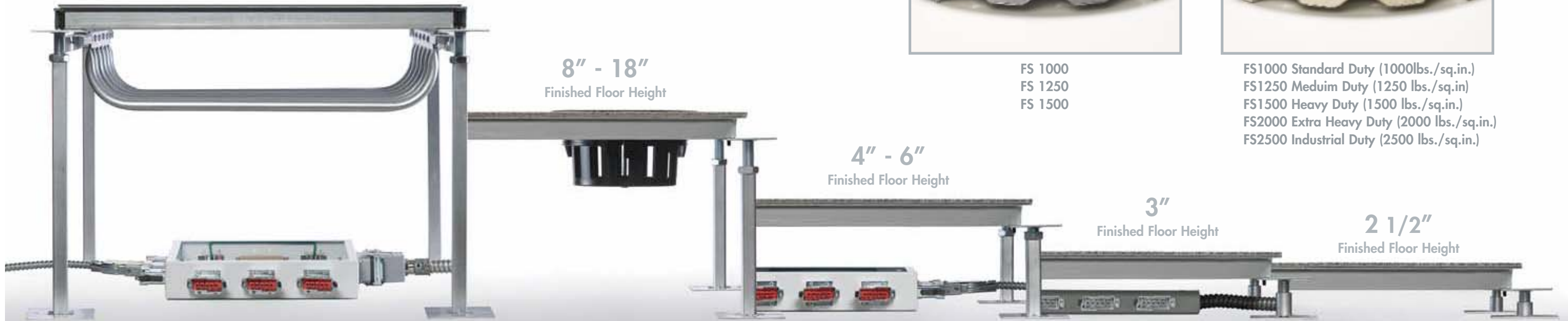

COMPUTER ROOMS/DATA CENTERS



UNDERFLOOR AIR OPTION

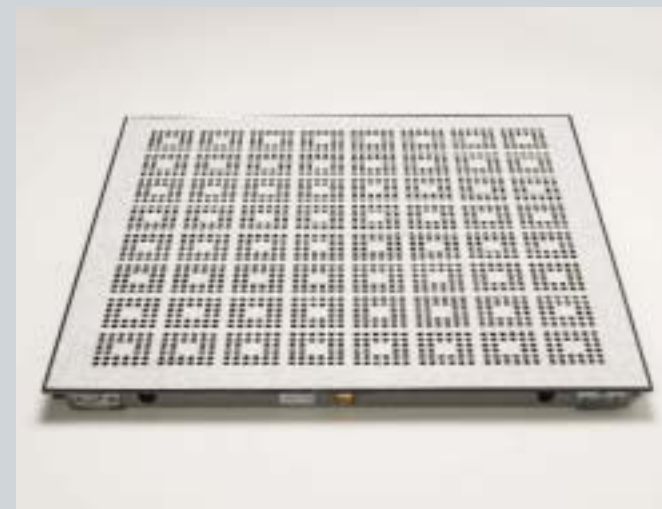

PERFORATED PANEL



BOLTED STRINGER



CORNER BOLT

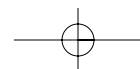

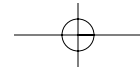

Camino Flex Plug and Play Modular Wiring

Designer Finishes



All boxes available in IG and dedicated power configurations



SDR 120-2D



SDR 120-3D



SDR 120-4D



Voice/data plates accommodate various manufacturer's connectors.



HARDWOOD

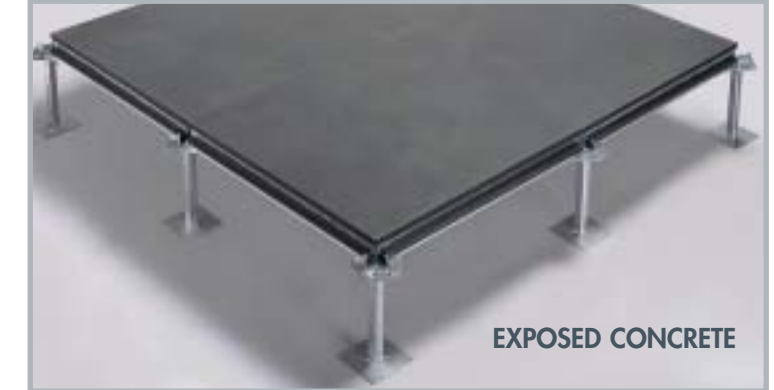

EXPOSED CONCRETE



CARPET TILE



STAINLESS STEEL



VINYL



LAMINATE

Camino flex plug and play wiring systems are compatible with all types of furniture systems

POWER DISTRIBUTION BOXES



Low profile design fits in 2 1/2" FFH floor system. Available in 4, 6, 9, or 12 port configurations. Factory pre-wired to suit project circuiting requirement.



Standard design available in 4, 6, 9, and 12 port configurations. Power out ports are labeled to ensure organized electrical installation.

CABLE SETS



Plug and play cable sets available in 3 to 10 wire configurations and lengths of 10 ft, 15 ft, 20 ft, 25 ft, 35 ft, 50 ft and 75 ft.



J box provides transition from electrified furniture systems.



GLASS



STONE

