

FS 2000 Series Access Floor System

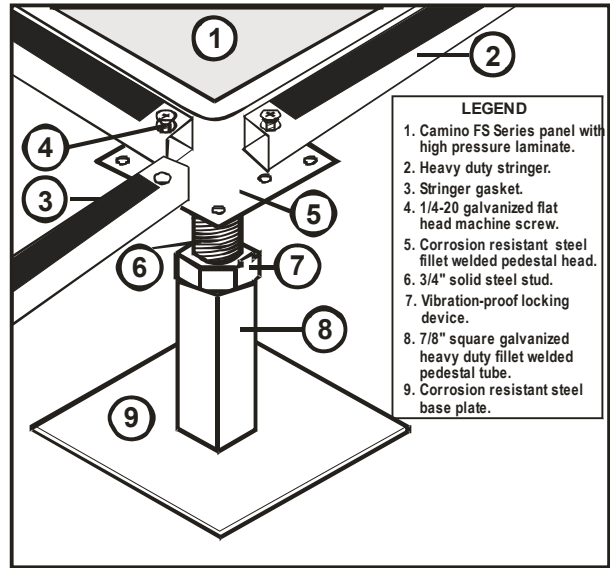

PANELS

FS2000/CR COMPUTER ROOM PANEL:

The combination of cementitious core strength and welded steel outer sheets have made this a superior and flexible panel to meet every building requirement.

The FS 2500/CR panel combines a die cut steel top sheet and die cut formed bottom pan that are structurally welded and injected with foamed cement. The surface covering is typically a high pressure laminate, or reinforced vinyl.

PANEL TYPE	2500/CR IMPERIAL	2500/CR METRIC
Concentrated Load*	2000 lbs.	8.9 kN
Uniform Load**	500 lbs.	27.56 kN/m2
Rolling Load ***	1500/1250 lbs.	6.7/5.56 kN
Ultimate Load*	6000 lbs.	26.7 kN
Size	24" x 24"	600 mm x 600 mm
Finished Floor Heights	3" to 60"	75 mm to 1500 mm
Understructure	Bolted Stringer	Bolted Stringer
Floor Finishes	High pressure Laminate Conductive Vinyl	High pressure Laminate Conductive Vinyl

*Measured on 1 sq.in. or 25 mm at any point.

**Measured on 1 sq.ft. or 30 cm x 30 cm area.

*** 3" diameter (76mm) x 1 13/16" wide (46mm) wheel/10" x 4" wheel.

Camino Modular Systems Inc. reserves the right to alter design engineering or specifications without incurring obligation and without prior notice.