

SC1500 Access Floor System

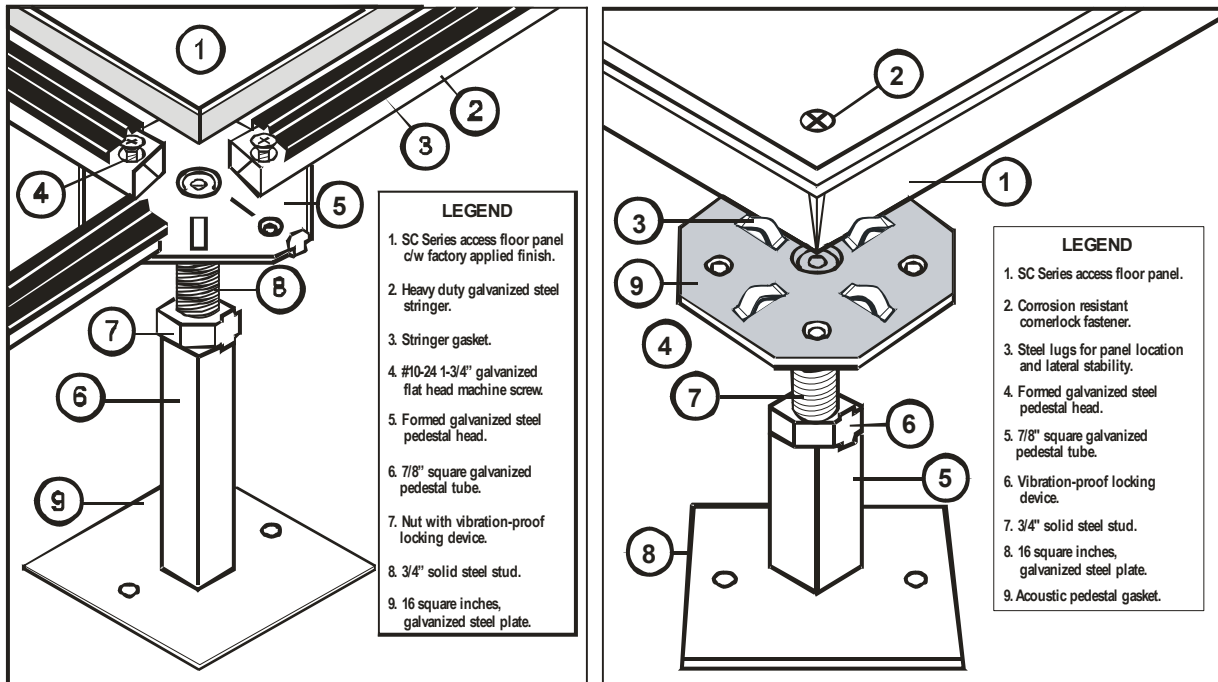

PANELS

SC1500/CR COMPUTER ROOM PANEL:

The combination of cementitious treated composite fiber core strength and galvanized steel outer sheets have made this a superior and flexible panel to meet every building requirement.

The SC1500 CR panel combines a die cut galvanized steel top sheet and die cut formed bottom pan that are structurally bonded to the cementitious treated composite fiber core with thermo setting adhesives. The surface covering is typically a high pressure laminate, or reinforced vinyl. All panels employ a mechanically locked trim. A positive plenum seal is created by identical panel squareness and a conductive vinyl stringer gasket.

SC1500/GO GENERAL OFFICE PANEL:

The combination of a cementitious treated composite fiber core and galvanized steel outer sheets provide superior acoustics.

The surface preparation is typically bare. Cornerlock design in conjunction with the high performance panel provides slab like underfoot performance.

PANEL TYPE	1500/CR IMPERIAL	1500/CR METRIC		1500/GO IMPERIAL	1500/GO METRIC
Design Load*	1500 lbs.	6.6 kN		1500 lbs.	6.6 kN
Uniform Load**	450 lbs.	205 kg.		400 lbs.	181 kg.
Rolling Load ***	1500 lbs./1000 lbs.	680 kg/454 kg.		1250 lbs./800 lbs.	566 kg/363 kg.
Safety Factor*	Min. 2.0	Min. 2.0.		Min. 2.0	Min. 2.0
Size	24" x 24"	600 mm x 600 mm		24" x 24"	600 mm x 600 mm
Finished Floor Heights	3" to 60"	75 mm to 1500 mm		2 1/2" to 24"	62 mm to 600 mm
Understructure	Bolted Stringer	Bolted Stringer		Cornerlock	Cornerlock
Floor Finishes	High pressure Laminate Conductive Vinyl	High pressure Laminate Conductive Vinyl		Free lay carpet tile Factory bonded carpet	Free lay carpet tile Factory bonded carpet

* Design Load is the load that can be applied to an access floor panel on actual understructure, which when the load is applied and released, the panel will not exceed the yield point (beyond 0.010" permanent set) and return to it's original state. The Design Load panel will also have an minimum Ultimate load of 2 X Design Load. Design and Ultimate loads are applied to a 1 square inch area of the panel at the weakest point of the system.

**Measured on 1 sq.ft. or 30 cm x 30 cm area.

*** 3" diameter (76mm) x 1 13/16" wide (46mm) wheel. /6" x 2" wheel.