

SC1000 Access Floor System

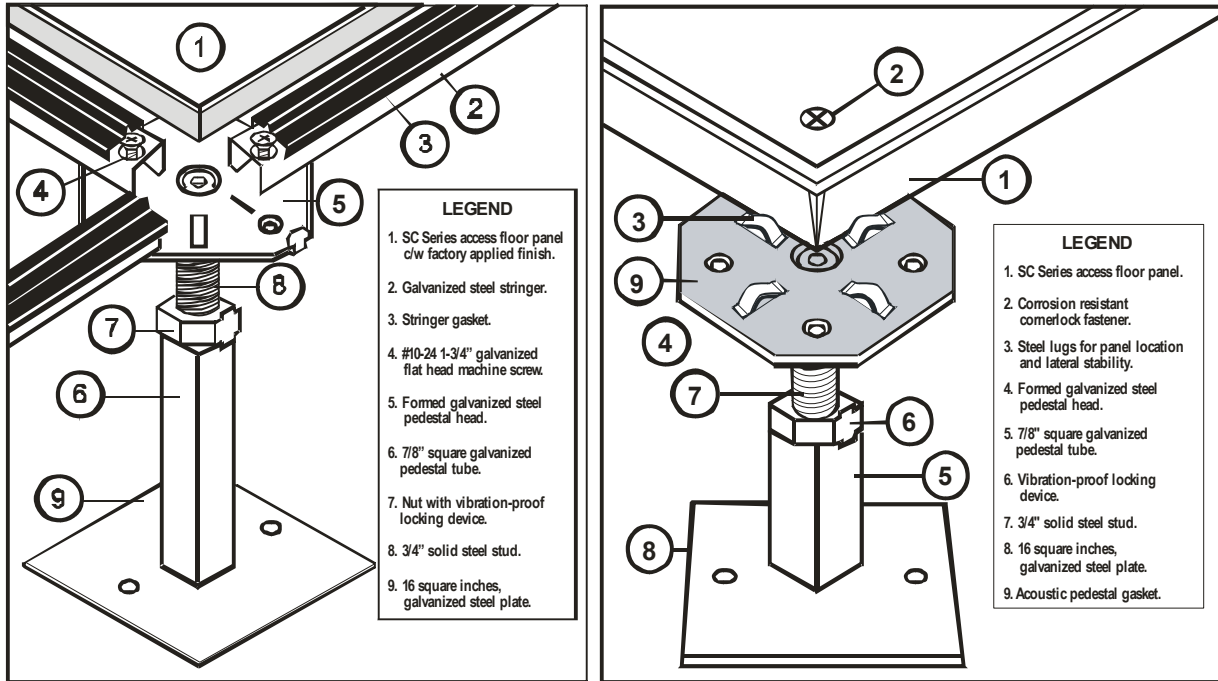

PANELS

SC1000/CR COMPUTER ROOM PANEL:

The combination of cementitious treated composite fiber core strength and galvanized steel outer sheets have made this a superior and flexible panel to meet every building requirement.

The SC1000 CR panel combines a die cut galvanized steel top sheet and die cut formed bottom pan that are structurally bonded to the cementitious treated composite fiber core with thermo setting adhesives. The surface covering is typically a high pressure laminate, or reinforced vinyl. All panels employ a mechanically locked trim. A positive plenum seal is created by identical panel squareness and a conductive vinyl stringer gasket.

SC1000/GO GENERAL OFFICE PANEL:

The combination of a cementitious treated composite fiber core and galvanized steel outer sheets provide superior acoustics.

The surface preparation is typically bare. Cornerlock design in conjunction with the high performance panel provides slab like underfoot performance.

PANEL TYPE	1000/CR IMPERIAL	1000/CR METRIC		1000/GO IMPERIAL	1000/GO METRIC
Concentrated Load*	1000 lbs.	4.4 kN		1000 lbs.	4.4 kN
Uniform Load**	250 lbs.	114 kg.		250 lbs.	114 kg.
Rolling Load ***	1000 lbs./600 lbs.	455 kg/272 kg.		1000 lbs./600 lbs.	455 kg/272 kg.
Minimum Ultimate Load*	2500 lbs.	1136 kg.		2300 lbs.	1043 kg.
Size	24" x 24"	600 mm x 600 mm		24" x 24"	600 mm x 600 mm
Finished Floor Heights	3" to 60"	75 mm to 1500 mm		2 1/2" to 24"	75 mm to 600 mm
Understructure	Bolted Stringer	Bolted Stringer		Cornerlock	Cornerlock
Floor Finishes	High pressure Laminate Conductive Vinyl	High pressure Laminate Conductive Vinyl		Free lay carpet tile Factory bonded carpet	Free lay carpet tile Factory bonded carpet

* Measured on 1 sq.in. or 25 mm².

**Measured on 1 sq.ft. or 30 cm x 30 cm area.

*** 3" diameter (76mm) x 1 13/16" wide (46mm) wheel. /6" x 1 1/2" wheel. CISCA